

Research Article

Agro-morphological and phytochemical diversity and silica content variability among Iranian populations of common horsetail (*Equisetum arvense* L.)

Mahdi Malekpour Irde-Mousa¹, Mohammad Hossein Mirjalili^{1,*}, Sara Rahimi¹, Ali Sonboli², Samad Nejad Ebrahimi³, Javad Hadian¹

¹ Department of Agriculture, Medicinal Plants and Drugs Research Institute, Shahid Beheshti University, 1983969411, Tehran, Iran

² Department of Biology, Medicinal Plants and Drugs Research Institute, Shahid Beheshti University, 1983969411, Tehran, Iran

³ Department of Phytochemistry, Medicinal Plants and Drugs Research Institute, Shahid Beheshti University, 1983969411, Tehran, Iran

ARTICLE INFO

ABSTRACT

Keywords:

Equisetaceae
Horsetail
Isoquercitrin
Silica
Variability

Background: Common horsetail (*Equisetum arvense* L.), is widely used in the bone and nail strengthen herbal products due to the presence of minerals, especially silica. **Objective:** Agro-morphological and phytochemical diversity, and the silica content of the *E. arvense* populations (*EAPs*) collected from Iran along with two commercial samples from Russia and Switzerland were investigated. **Methods:** Morphological traits were measured using ruler, digital caliper, naked eye, and digital balance. Phytochemical characteristics were assessed by spectrophotometer and HPLC-PDA analyses. Silica content was measured by Energy-dispersive X-ray spectroscopy (EDAX) analysis. **Results:** The maximum height was observed in Sarab (*EAP4*), while the highest width and stem dry weight was found in Marzanabad (*EAP11*). The highest TPC and TFC were measured in the Russian and *EAP11* samples, respectively. Isoquercitrin content was varied from 0.03 (Russian) to 3.05 mg/g DW (*EAP11*) based on HPLC analysis while silica content was different among samples from 30 to 87.5 mg/g DW in *EAP9* and *EAP1*, respectively. **Conclusion:** In this study, *EAP11* and *EAP4* were superior in terms of important morphological traits. Marzanabad (*EAP11*) was a superior population in phytochemical characteristics which can be strongly recommended for further exploitation in conservation, domestication, and mass production programs. In the case of silica content, the *EAP1* was characterized as the superior population which can be interesting for further exploitation in the production of bone, hair, and nail strengthening herbal products.

Abbreviations: MAPs, Medicinal and Aromatic Plants; *EAPs*, *E. arvense* Populations; TPC, Total Phenol Content; TFC, Total Flavonoid Content; MPH, Herbarium of Medicinal Plants and Drugs Research Institute; DW, Dry Weight; DMSO, Dimethyl Sulfoxide; PDA, Photodiode Array; HPLC, High-Performance Liquid Chromatography; EDAX, Energy-Dispersive X-Ray Spectroscopy; SEM, Scanning Electron Microscope; SMs, Secondary Metabolites.

*Corresponding author: m-mirjalili@sbu.ac.ir

doi: 10.52547/jmp.20.80.83

Received 16 October 2021; Received in revised form 30 November 2021; Accepted 30 November 2021

© 2020. Open access. This article is distributed under the terms of the Creative Commons Attribution-NonCommercial 4.0 International License (<https://creativecommons.org/licenses/by-nc/4.0/>)

1. Introduction

Many countries throughout the world supply herbal raw materials collected from natural sources and pastures for use in the traditional medicine, pharmaceutical, and cosmetic industries. Little attention has been paid to *in-situ* and *ex-situ* cultivation of these plants for further conservation and restoration of their natural habitats [1, 2]. The growth of the world market for medicinal and aromatic plants (MAPs) led to a decline in the quantity and quality of the plant materials, over-collection and extinction of many of them in the nature, as well. Medicinal and aromatic plants are the world's genetic reserves that can play a vital role in community health, employment, and economic income if they are scientifically identified, cultivated, developed, and exploited [3, 4].

Herbal plants growing in nature contain proprietary phytochemicals and are valuable genetic resources that should be kept in support of community-based medicines in nature. Indeed, the study of morphological and phytochemical diversity among wild populations of MAPs, is one of the essential stages of their domestication, cultivation, improvement, and commercial production in agricultural systems. Such like investigations have been accomplished for several MAPs including *Ruscus hyrcanus* Woron. [5], *Verbascum songaricum* Shrenk [6], *Satureja khuzistanica* Jamzad [7].

Equisetum L. with the common Persian name of "Dom-e-Asb", is the only genus of the Equisetaceae family comprising fifteen species with gametophytic and sporophytic growth stages which are distributed throughout the world. Four species of *Equisetum*, including *E. arvense* L., *E. telmateia* Ehrh., *E. paluster* L. and *E. ramosissimum* Desf. are commonly growing in the flora of Iran [8, 9]. *Equisetum arvense* is a rhizomatous perennial herbaceous plant rich in silica which is distributed in northern to northwestern areas of Iran [9].

The aerial parts of *E. arvense* are traditionally used to treat osteoporosis, tuberculosis, repair bone fractures, bladder and kidney problems, and to stop bleeding [10]. The plant is also rich in caffeic acid, tartaric acid, quercetin, *p*-coumaric acid, and isoquercitrin (C₂₁H₂₀O₁₂) [11]. Various pharmacological effects of *E. arvense* such as antidiabetic, anti-inflammatory, anti-anxiety, anti-anemic, antioxidative, anticancer, anesthetic, hair and nail strengthening, liver protection, improving cardiovascular problems, and wound healing have been reported [10, 12, 13]. The cultivation of the plant has not been commercially introduced into crop systems so far. The herbal medicines produced from *E. arvense* are proprietary and the needed plant materials are commonly collected from nature. Currently, Russia, followed by Hungary, Poland, and China are the largest suppliers of horsetail materials in the world. Some commercial herbal products formulated from the horsetail. Recently, tablet and an herbal lotion from the aerial parts of *E. arvense* have been launched to the herbal markets in Iran.

Given the economic importance of the plant, its domestication, cultivation, and commercial production process are very important to meet the demand of the pharmaceutical, cosmetic, and health industries. As far as the literature survey could ascertain, agro-morphological and phytochemical diversity of Iranian *E. arvense* populations (*EAPs*) has never been studied. The present study aimed to introduce the superior population(s) based on phenotypic characteristics, total phenol content (TPC), total flavonoid content (TFC), silica, and isoquercitrin contents from Iran. This information can be considered by the MAPs producers to use the high-yielding horsetail population for further domestication, breeding, and commercial exploitation.

2. Materials and Methods

2.1. Chemicals

Methanol, acetic acid, and acetonitrile HPLC grade were purchased from Merck Company (Darmstadt, Germany). HPLC grade water was prepared by the Mili-Q machine (Merck Millipore, USA). Authentic isoquercitrin, *p*-coumaric acid, quercetin, and gallic acid were purchased from Sigma-Aldrich, Inc (Germany).

2.2. Plant materials

The aerial parts of the 11 *EAPs* were collected from different geographical regions of Iran, including East Azerbaijan, Ardabil, Mazandaran, and Alborz Provinces during June to July 2018 (Fig. 1). The geographical information of each collection site is represented in Table 1. Two samples of *E. arvense* were obtained from Russia and Switzerland for further comparison. From each population, 10 individuals of the same age

were collected. The distance between the sampled individuals and populations in each collection site was at least 100 m and 2 km, respectively. The plant vegetative organs were dried in the shade at room temperature and kept in a cool and dry place in the bags until analysis. The voucher specimens of identified plant samples have been deposited at the Herbarium of Medicinal Plants and Drugs Research Institute (MPH), Shahid Beheshti University, Tehran, Iran (Table 1).

2.3. Morphological analysis

Six phenotypic characters including plant height, plant width, number of nodes, internode length, internode diameter, and dry weight related to the vegetative growth of different *EAPs* were measured using ruler, digital caliper, naked eye, and digital balance.

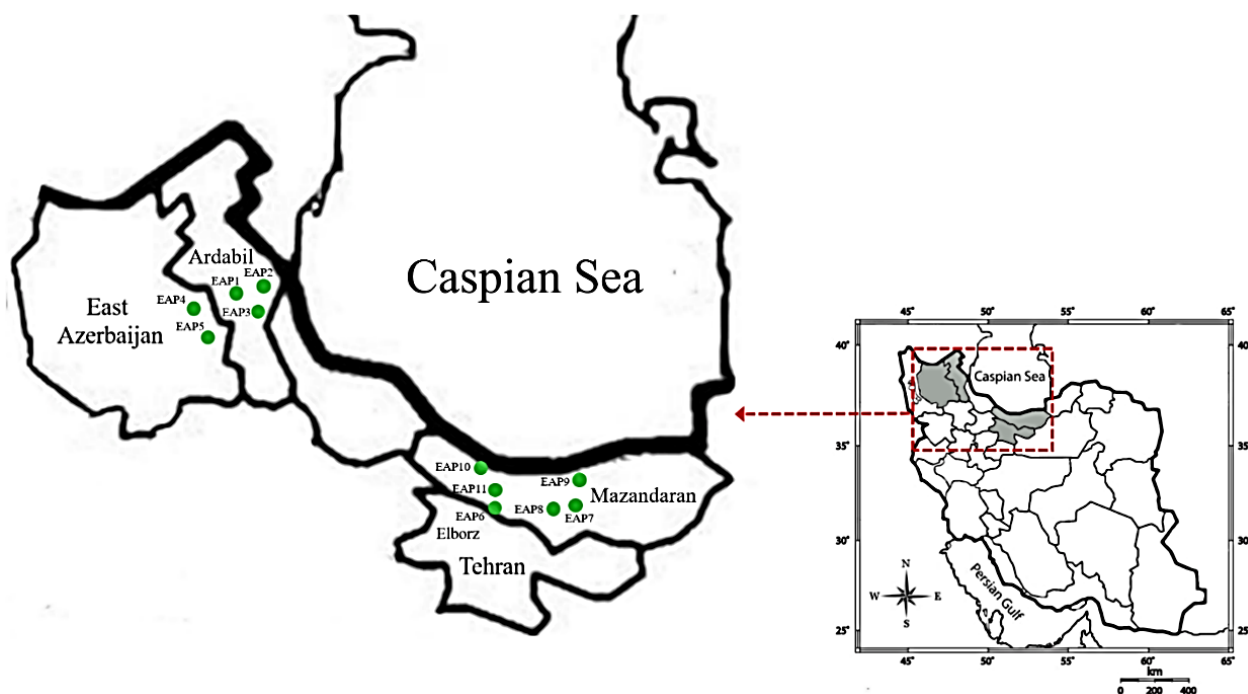

Fig. 1. Geographic distribution of the studied *Equisetum arvense* populations (*EAP1-EAP11*). For a detailed description of collection sites, cf. Table 1

Table 1. Localities and geographical characteristics of the studied *Equisetum arvense* populations (EAP)

No.	Population name	Code	Location	Voucher specimen No.
1	Irde-Mousa	EAP1	Ardabil	MPH-2249
2	Hir	EAP2	Ardabil	MPH-2252
3	Namin	EAP3	Ardabil	MPH-2251
4	Sarab	EAP4	East Azerbaijan	MPH-2250
5	Kandovan	EAP5	East Azerbaijan	MPH-2448
6	Tunnel-e-Kandovan	EAP6	Alborz	MPH-2449
7	Takor	EAP7	Mazandaran	MPH-2247
8	Yush	EAP8	Mazandaran	MPH-2248
9	Chamestan	EAP9	Mazandaran	MPH-2245
10	Abbasabad	EAP10	Mazandaran	MPH-2246
11	Marzanabad	EAP11	Mazandaran	MPH-2450

Table 2. Localities and geographical characteristics of the studied *Equisetum arvense* populations (EAP) (Continued)

No.	Population name	Climatic conditions					
		Latitude (N)	Longitude (E)	Elevation (m)	AAT (°C)	AP (mm)	RH (%)
1	Irde-Mousa	38° 11'	48° 75'	1517	9.4	295	74
2	Hir	38° 04'	48° 30'	1570	8.9	325	73
3	Namin	38° 23'	48° 32'	1448	9.2	402	72
4	Sarab	37° 57'	47° 52'	1880	8.7	320	60
5	Kandovan	37° 52'	46° 11'	2300	12.3	342	49
6	Tunnel-e-Kandovan	36° 15'	51° 35'	3030	10.7	508	76
7	Takor	36° 12'	52° 10'	1730	10.7	451	62
8	Yush	36° 11'	51° 42'	2230	10.7	451	62
9	Chamestan	36° 18'	52° 70'	1103	17.4	702	77
10	Abbasabad	36° 32'	53° 25'	619	16.4	1206	83
11	Marzanabad	36° 44'	51° 29'	930	10.7	504	76

AAT, average annual temperature, AP, annual precipitation, RH, relative humidity

2.4. Extraction procedure

Air-dried aerial parts of the plant samples (200 mg) were drenched in 10 ml methanol for 20 min and subjected to ultrasonic-assisted extraction for 20 min three times. The obtained extracts were centrifuged at 4000 rpm for 15 min and the supernatant was concentrated using a rotary vacuum evaporator (Heidolph, Germany). The dried extracts were kept in the refrigerator at 4 °C until analysis.

2.4.1. Measurement of total phenol and total flavonoid content

Total phenol content was measured using the Folin-Ciocalteu method [14]. For instance, 25 µL of extract solution (1000 µg/ml) was mixed with 125 µL of 10 % Folin-Ciocalteu reagent. Following a 5 min incubation period, 100 µL sodium carbonate solution (Na₂CO₃) 7.5 % (W/V) was added into 96 well plate. The plate was then covered with aluminum foil and placed on a shaker at 80 rpm for two hours. Then the

absorbance was measured at a wavelength of 760 nm using a Microplate spectrophotometer (Bio-Tek Instruments, Inc., USA). Eight concentrations of gallic acid (6.25-1000 µg/ml) were used to perform a calibration curve ($y = 0.0034x + 0.1955$, $r^2 = 0.9929$) as a positive control. The amount of total phenolic compounds was measured as mg gallic acid equivalent per gram of dry extract (mg GAE/g dry weight).

Total flavonoid content measured using sodium hydroxide (NaOH) 4 % solution, sodium nitrite (NaNO₂) 5 %, and aluminum chloride (AlCl₃) 10 % in distilled water for testing. For each sample, 25 µl of the sample solution, along with 100 µl of distilled water and 7.5 µl of NaNO₂ solution (n = 3) were poured into 96 well plate. After six minutes, 7.5 µl of AlCl₃, 100 µl of NaOH, and 10 µl of distilled water were added to each well. The absorption was read after 15 minutes at a wavelength of 510 by the spectrophotometer. Seven concentrations of quercetin (12.5-1000 µg/ml), solved in methanol was used as standards to plot calibration curves ($y = 0.0003x + 0.0442$, $r^2 = 0.9998$). Total flavonoid content was measured as mg quercetin equivalent per gram of dry extract (mg QE/g dry weight) through the resulting equation from the standard curve [15]. Experiments were carried out with three replications, and the mean values were reported.

2.4.2. HPLC-PDA and LC-MS analyses

Methanolic extract (10 mg/ml) of the plant samples was dissolved in dimethyl sulfoxide (DMSO) and particles have been removed using a syringe filter (0.45 µm PTFE). The extracts qualitatively analyzed by LC-MS using Shimadzu Prominence system equipped with LC-20 AD binary pump, column oven, a photodiode array (PDA) detector (SDP-M20A), and system manager (CBM-20A) coupled with

Triple Quadrupole Mass (MS-8030) spectrometer with an electrospray ionization source (ESI). Full-scan (160-1500) was carried out with 6000 u/sec scan speed and 0.150 s per event time. Data acquisition was performed with Lab Solutions software (Shimadzu).

The Waters 2695 High-Performance Liquid Chromatography (HPLC) system was equipped with a photodiode array (PDA) detector (SDP-M20A) and a Sunfire C₁₈ column (100Å, 3.5 µm, 3 mm × 150 mm). The mobile phase consists of water with 2.5 % acetic acid (A) and acetonitrile (B). The gradient elution system used for separation of methanol extract starting with 14 % B and hold for 15 min, reached 23 % B in 10 min, 100 % B in 10 min and kept for 5 min. The flow rate was 0.4 ml/min. The chromatograms were recorded at the wavelengths of 227 and 335 nm. To obtain the calibration curves of isoquercitrin and *p*-coumaric acid, 1 mg of each standard was dissolved in methanol to prepare a stock solution. The serial dilutions for isoquercitrin were made from 100, 50, 25, 10 and 1 ppm and those of *p*-coumaric acid were prepared from 125, 64.5, 32.5, 16.4, 8.2, 4.1, and 2.0 ppm and analyzed by HPLC-PDA.

2.5. Silica content measurement

Powdered air-dried aerial parts of the plant samples (1 g) were soaked in 250 ml of distilled water and were then shaken for 30 min on a Heater Stirrer at 300 rpm. After dehydration, they were placed in the oven for drying at 100 °C for 12 h. Oven-dried samples were then drenched in 49.6 ml HCl in a volume of 200 ml (4:1) and then reflux was performed for 1 h. After cooling, the plant sample was dehydrated with filter paper again and placed in the oven at 100 °C for 12 hours. The sample was then re-weighed and placed in an oven at 650 °C for 9 h. Finally, the sample was taken and weighed with a digital

balance. Finally, silica content was measured by Energy-dispersive X-ray spectroscopy (EDAX) and scanning electron microscope (SEM, model 3500, Hitachi, Japan).

2.6. Statistical analysis

Experiments were accomplished in triplicate and analysis of variance for morphological traits, correlation, and cluster analysis were applied using the SPSS software Version 23 (SPSS Inc., Chicago, IL, USA). Significant differences between means found out using Tukey's multiple range test ($P < 0.05$).

3. Results

3.1. Habitat characterization of *Equisetum arvense* populations

As can be seen in Table 1 and Fig. 1, the studied *E. arvense* populations (*EAP1-EAP11*) are geographically distributed within the latitude of $36^{\circ} 11'$ to $38^{\circ} 23'$ N and longitude of $46^{\circ} 11'$ to $53^{\circ} 25'$ E surrounding different geographical regions from the northwest to the north of Iran. Most of Iranian *EAPs* including *EAP1*, *EAP2*, *EAP3*, and *EAP11* are located in temperate mountain climate characterized by a mean rainfall of 295-504 mm/year and annual temperature of 8.9-10.7 °C. The habitats of *EAP7* and *EAP8* with a 25 km distance are characterized by a temperate-cold and semi-humid climate. These regions were similar in geographical parameters except altitude and longitude. The distribution habitat of some *EAPs* is shown in Fig. 2.



Fig. 2. Distribution habitats of some *Equisetum arvense* populations collected in the present study. A: Irde-Mousa (*EAP1*), B: Hir (*EAP2*), C: Namin (*EAP3*), D: Tunnel-e-Kandovan (*EAP6*), E: Takor (*EAP7*), F: Yush (*EAP8*), G: Abbasabad (*EAP10*), H: Marzanabad (*EAP11*).

The habitats of *EAP6*, *EAP9*, and *EAP10* are humid-temperate climate. The maximum annual rainfall (1206 mm/year) and relative humidity

(83 %) were reported from the habitat of *EAP10* (Abbasabad). The highest mean annual temperature (17.4 °C) was related to *EAP9* habitat (Table 1). The highest (3030 m) and the lowest (619 m) altitude were belonged to the habitats of *EAP6* (Tunnel-e-Kandovan) and *EAP10* (Abbasabad), respectively. Populations of Sarab (*EAP4*) and Kandovan (*EAP5*) are growing in the mountain and cold regions of East Azerbaijan with mean annual rainfall ranged from 320 to 342 mm/year, the lowest mean temperature (8.7 °C) and relative humidity (49 %). It has been concluded that *EAPs* are distributed in the temperate and humid regions with the upper level of water table. The highest plant density was observed in Yush (*EAP8*) followed by Kandovan (*EAP5*), and Irde-Mousa (*EAP1*).

3.2. Morphological diversity

The results of variance analysis on morphological data showed that the measured traits including stem diameter, internode length, number of nodes, width, height and plant dry weight were significant at 5 % probability level among the studied *EAPs* (Table 2). Mean comparison of measured morphological characteristics including stem diameter, internode length, number of nodes, plant width, height, and dry weight among *EAPs* have been depicted in Table 3. The plant height is the most important characteristic among wild plant populations. While, Marzanabad (*EAP11*) with the greatest plant width (8.75 cm), number of nodes (18.9) and stem dry weight (1.31 g) was the superior population, but Sarab (*EAP4*) was found to be the superior population comprising the highest plant height (39.67 cm) and internode length (36.24 mm). Analysis of the variance revealed significant differences ($P < 0.05$) among the studied *EAPs*.

Table 2. Analysis of variance (ANOVA) for the studied morphological traits among *Equisetum arvense* populations (EAP)

Source of variation	df	Mean of square		
		Plant height (cm)	Plant width (cm)	Stem diameter (mm)
Population	10	486.104*	26.408*	0.532*
Error	99	21.866	6.112	0.090
CV (%)		21.56	32.38	20.26

Table 2. Analysis of variance (ANOVA) for the studied morphological traits among *Equisetum arvense* populations (EAP) (Continued)

Source of variation	Mean of square		
	Internode length (mm)	Number of node	Stem dry weight (g)
Population	418.053*	68.989*	0.716*
Error	57.363	6.112	0.118
CV (%)	27.03	16.43	46.82

*: Significantly different at the 5 % probability level

Table 3. Mean comparison of morphological characteristics among *Equisetum arvense* populations (EAP)

No.	Population name	Code	Morphological traits	
			Plant height (cm)	Plant width (cm)
1	Irde-Mousa	EAP1	34.42 ^{ab}	4.94 ^{cd}
2	Hir	EAP2	29.96 ^{bc}	6.80 ^b
3	Namin	EAP3	33.50 ^b	6.07 ^{bcd}
4	Sarab	EAP4	39.67 ^a	6.96 ^b
5	Kandovan	EAP5	23.60 ^d	6.51 ^{bc}
6	Tunnel-e-Kandovan	EAP6	32.75 ^b	5.54 ^{bcd}
7	Takor	EAP7	22.03 ^d	4.84 ^{cd}
8	Yush	EAP8	25.76 ^{cd}	5.45 ^{bcd}
9	Chamestan	EAP9	15.82 ^e	2.91 ^e
10	Abbasabad	EAP10	22.14 ^d	4.74 ^d
11	Marzanabad	EAP11	30.46 ^{bc}	8.75 ^a

Table 3. Mean comparison of morphological characteristics among *Equisetum arvense* populations (EAP) (Continued)

No.	Population name	Morphological traits			
		Stem diameter (mm)	Internode length (mm)	Number of node	Stem dry weight (g)
1	Irde-Mousa	1.82 ^a	28.16 ^{bcd}	18.90 ^a	0.68 ^{bc}
2	Hir	1.62 ^{abc}	32.01 ^{abc}	13.77 ^{de}	0.67 ^{bc}
3	Namin	1.39 ^{cdef}	34.61 ^{ab}	15.40 ^{bcd}	0.85 ^b
4	Sarab	1.58 ^{abc}	36.24 ^a	16.10 ^{bc}	0.80 ^b
5	Kandovan	1.15 ^{ef}	22.23 ^d	11.88 ^{ef}	0.45 ^{cd}
6	Tunnel-e-	1.73 ^{ab}	37.67 ^a	16.70 ^{ab}	0.73 ^{bc}
7	Takor	1.40 ^{cde}	23.18 ^d	13.90 ^{cde}	0.66 ^{bc}
8	Yush	1.52 ^{bcd}	27.27 ^{cd}	15.60 ^{bcd}	0.49 ^{cd}
9	Chamestan	1.13 ^f	16.05 ^e	11.50 ^f	0.33 ^d
10	Abbasabad	1.29 ^{def}	26.17 ^{cd}	11.80 ^{ef}	0.36 ^d
11	Marzanabad	1.63 ^{abc}	26.26 ^{cd}	18.90 ^a	1.31 ^a

Different letters indicate a 5 % probability level

Table 4. The correlation coefficient of morphological traits in the studied *Equisetum arvense* populations

Trait	Stem diameter	Internode length	Number of nodes	Plant width	Plant height	Stem dry weight
Stem diameter						
Internode length	0.651*	1				
Number of nodes	0.871**	0.504	1			
Plant width	0.364	0.447	0.424	1		
Plant height	0.723*	0.865**	0.675*	0.635*	1	
Stem dry weight (g)	0.516	0.413	0.723*	0.806**	0.602*	1

** and * respectively, at a probability level of 1 % and 5 %.

Plant height and internode length in *E. arvense* had a significant correlation ($P < 0.05$) with stem diameter (Table 4). Also, plant height had a significant correlation with number of nodes and plant width ($P < 0.05$). Also, dry matter of dry shoot weight was negatively correlated with the annual temperature ($P < 0.05$).

Also, plant height had a significant correlation with number of nodes and plant width ($P < 0.01$). To evaluate the variation among the studied *EAPs*, a cluster analysis (CA) was performed using six evaluated morphological traits. According to the result of the CA analysis, the studied genotypes were placed into two main groups of A and B (out groups) at a Euclidean distance of 25 (Fig. 3). Group A was divided into two main subgroups A1 and A2. Subgroup A1 includes populations of Hir (*EAP2*), Namin (*EAP3*), Sarab (*EAP4*), Tunnel-e-Kandovan (*EAP6*), Irde-Mousa (*EAP1*), and Marzanabad (*EAP11*). The populations of Hir, Namin, Sarab, and Tunnel-e-Kandovan were separated from the two populations of Irde-Mousa and Marzanabad by having the highest plant length and height. The last two populations (*EAP1* and *EAP11*) are well differentiated in the number of nodes with the other populations. Subgroup A2 included populations of Kandovan (*EAP5*), Takor (*EAP7*), Yush (*EAP8*), Chamestan (*EAP9*), and Abbas Abad (*EAP10*). The population of Chamestan had the lowest mean of morphological traits and were separated from the other populations. The rest populations of this subgroup were similar in the number of nodes, plant height, and dry weight, which clustered them together (Fig. 3).

The habitats of Hir (*EAP2*), Namin (*EAP3*), Sarab (*EAP4*), and Tunnel-e-Kandovan (*EAP6*) are suitable for the growth and development of horsetail due to their high altitude and cool climate, where the plants with similar morphological characteristics usually grow under the shade of trees on the northern slopes. The habitats of Takor (*EAP7*) and Yush (*EAP8*) with less than 40 km distance are similar in climate. The habitat of Kandovan has an equal altitude approximately. Despite the low altitude and relative humidity, the habitat of Abbasabad was grouped with the populations mentioned above. In the habitat of Chamestan, the plants grow slowly due to their location alongside the river margin and exposure to floods and pebbles. Therefore, the *EAP9* had lower plant height and dry weight (Table 3). So, these populations can be used in domestication and selection programs to obtain high-yielding cultivars.

3.3. Total phenol and total flavonoid content

A comparison of TPC (mg GAE/g DW) among the studied *EAPs* (Fig. 4A) showed that the maximum (3.34) and the minimum (0.84) TPC were measured in Marzanabad (*EAP11*) and Kandovan (*EAP5*), respectively. Total phenol content in the *EAPs* from Russia and Switzerland was 6.1 and 1.88 mg GAE/g DW, respectively.

The results of the TFC assay revealed that the highest and the lowest TFC (mg quercetin/g DW) among *EAPs* were found in the Marzanabad (12.28) and Takor (5.22), respectively (Fig. 4B). The populations from Russia and Switzerland contained 5.12 and 5.04 mg quercetin/g DW, respectively.

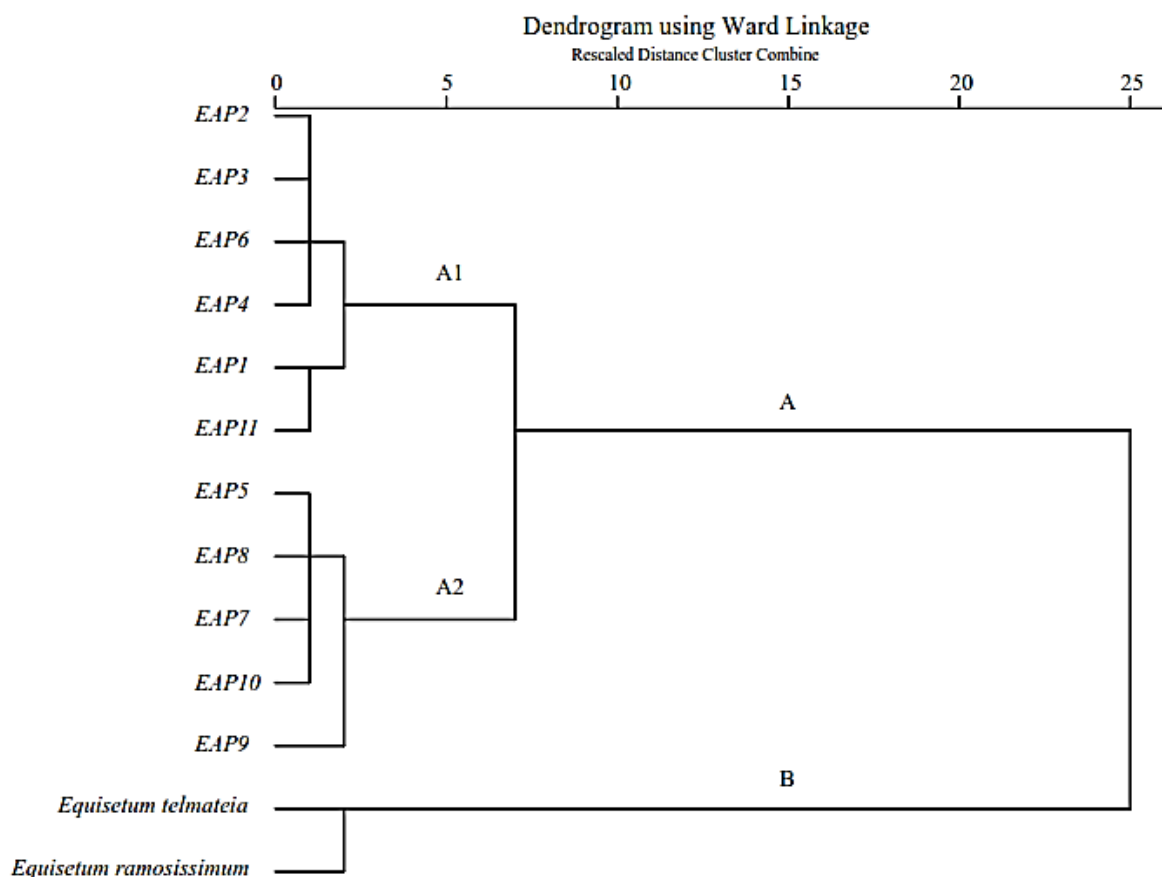

Fig. 3. Dendrogram analysis of the eleven *Equisetum arvense* populations (*EAPs*) based on morphological traits.

3.4 Isoquercitrin and *p*-coumaric acid content variability

To evaluate the phytochemical diversity of the studied *EAPs*, a comparative analysis of the isoquercitrin and *p*-coumaric acid was performed by HPLC-PDA analysis. Fig. 5 shows the typical HPLC-PDA-MS profiling of the methanolic extract of *E. arvens*. The highest and the lowest content of isoquercitrin were observed in the populations of Marzanabad (3.05 mg/g DW) and Hir (0.52 mg/g DW), respectively (Fig. 6A). The population from Russia contained 0.30 mg/g DW isoquercitrin, while the content of this compound in the population of Switzerland was 0.16 mg/g DW. The maximum (0.55 mg/g DW) and the minimum (0.008 mg/g DW) content of

p-coumaric acid were found in the populations of Marzanabad (*EAP11*) and Chamestan (*EAP9*), respectively (Fig. 6B). This compound was not detected in the populations of Takor (*EAP7*), Namin (*EAP3*), Russia, and Switzerland.

3.5 Correlation of environmental factors with phytochemicals in *E. arvense*

According to the results presented in Table 5, the correlation of environmental factors with phytochemical diversity showed that TFC was positively and significantly correlated with the content of isoquercitrin ($P < 0.05$). Also, dry matter of dry shoot weight was negatively correlated with the annual temperature at the probability level of 5 %.

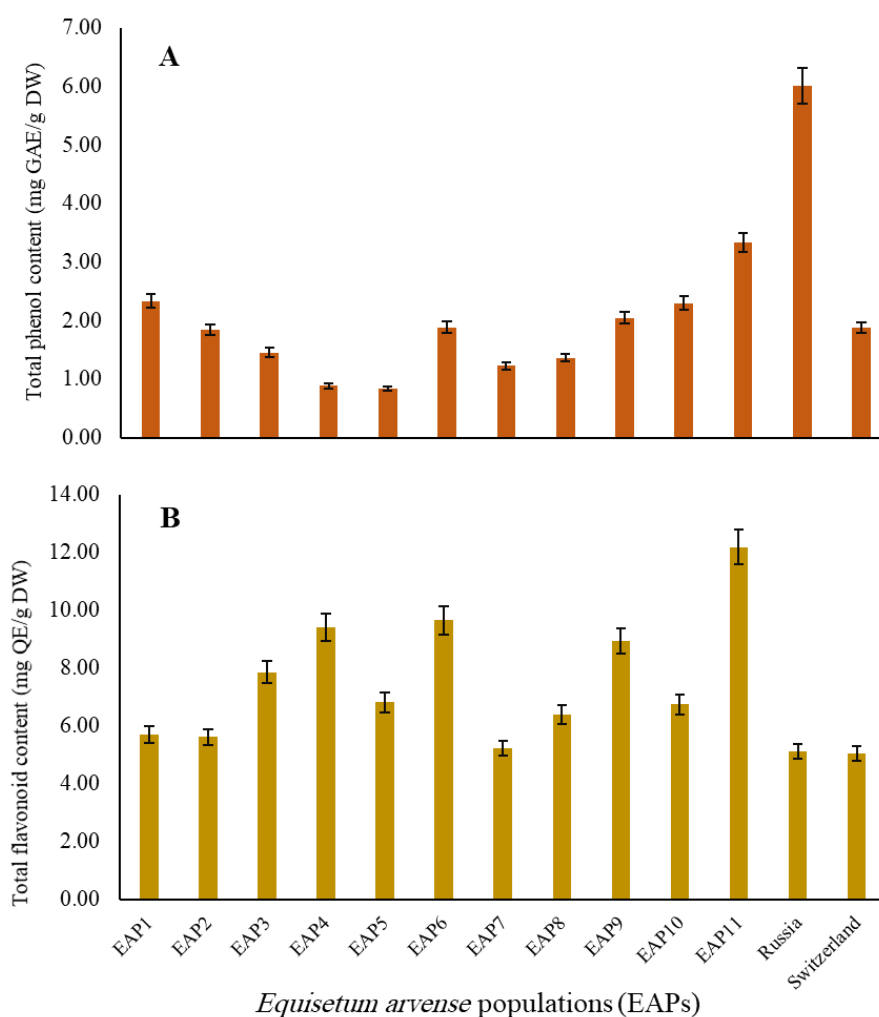

Fig. 4. Total phenol content (A) and total flavonoid content (B) of the studied *Equisetum arvense* populations (EAP1-EAP11). GAE, gallic acid equivalent; QE, quercetin equivalent.

Table 5. The correlation coefficient of environmental parameters and phytochemicals in the studied *Equisetum arvense* populations

Trait	IQC	TPC	TFC	SiC (%)	Altitude (m)	SDW (g)	AT (°C)
Isoquercitrin (IQC)	1						
Total phenol content (TPC)	0.396	1					
Total flavonoid content (TFC)	0.822**	0.441	1				
Silicon content (SiC)	0.099	0.169	-0.089	1			
Altitude (m)	0.059	-0.554	-0.065	0.057	1		
Stem dry weight (SDW)	0.505	0.433	0.600	0.273	-0.068	1	
Annual temperature (°C)	0.138	0.218	0.067	-0.275	-0.423	-0.609*	1

** and * at a probability level of 1 % and 5 %, respectively.

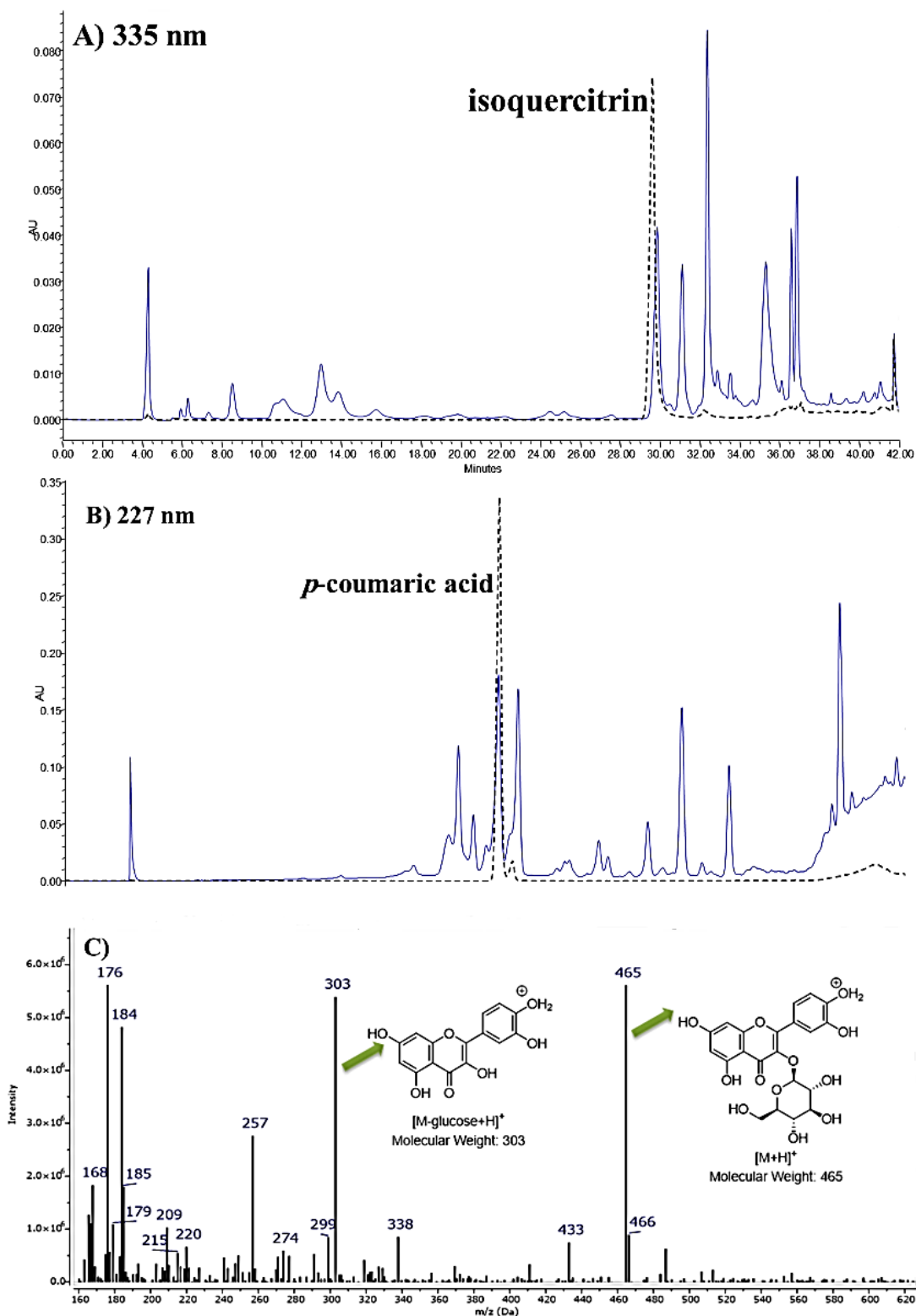

Fig. 5. A representative HPLC-PDA profiling of the methanolic extract of *Equisetum arvense*. HPLC-PDA chromatogram recorded at 335 (A) and 227 nm (B), mass spectrum ($[M+H]^+$ 465, $[M\text{-glucose}+H]^+$ 303) shows the fragmentation pattern of the isoquercitrin (C)

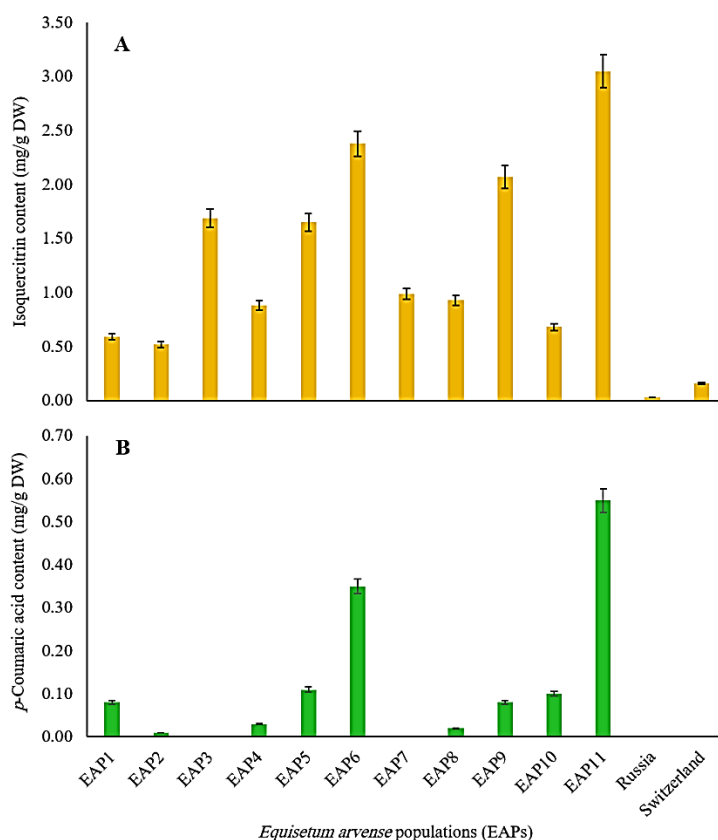

Fig. 6. Variability in the content of isoquercitrin (A) and *p*-coumaric acid (B) of the studied *Equisetum arvense* populations (EAP1-EAP11).

3.6. Silica content

To identify the type of accumulated silica in our studied samples, energy-dispersive X-ray spectroscopy analysis was performed (Fig. 7). In the present study, the silica content of the eleven Iranian *EAPs* was measured. The results revealed that about 98 % of the ash of *Equisetum* species was silica as SiO₂ containing 65 % atomic silica and 34 % atomic oxygen. In addition to silica, there is a very small percentage of aluminum (Al) as well as gold, most likely gold coated on the sample. Scanning electron microscopy analysis of the plant ash is shown in Fig. 8. This analysis was considered as a helpful tool to examine the surface morphology of the horsetail ash. As demonstrated, silicon was found at its highest amount in the outer edge of the plant ash. Besides, it appeared as if the ash preserved the

original structure of the plant. As shown in Fig. 8, it can be also estimated that the elimination of organic compounds resulted in the development of a higher surface area and porosity for the plant's ash in which provide a greater contact area.

A comparison of the percentage of silicon element in silica composition showed that the highest and the lowest content of silicon in *E. arvense* was 46.9 and 42.3 % in Marzanabad (EAP11) and Sarab (EAP4), respectively (Table 6). The percentage of oxygen in the silica composition of EAP4 (Sarab) and EAP7 (Takor) was in the highest (56.6 %) and the lowest (49.8 %) level, respectively. The maximum percentage of the aluminum element (3.7 %) was measured in the silica composition of Takor

(EAP7), while the minimum percentage (1 %) was observed in EAP4 (Sarab), EAP5 (Kandovan), and EAP11 (Marzanabad).

According to the obtained results, the content of silica was not correlated with the altitude of the plant collection sites (Table 5).

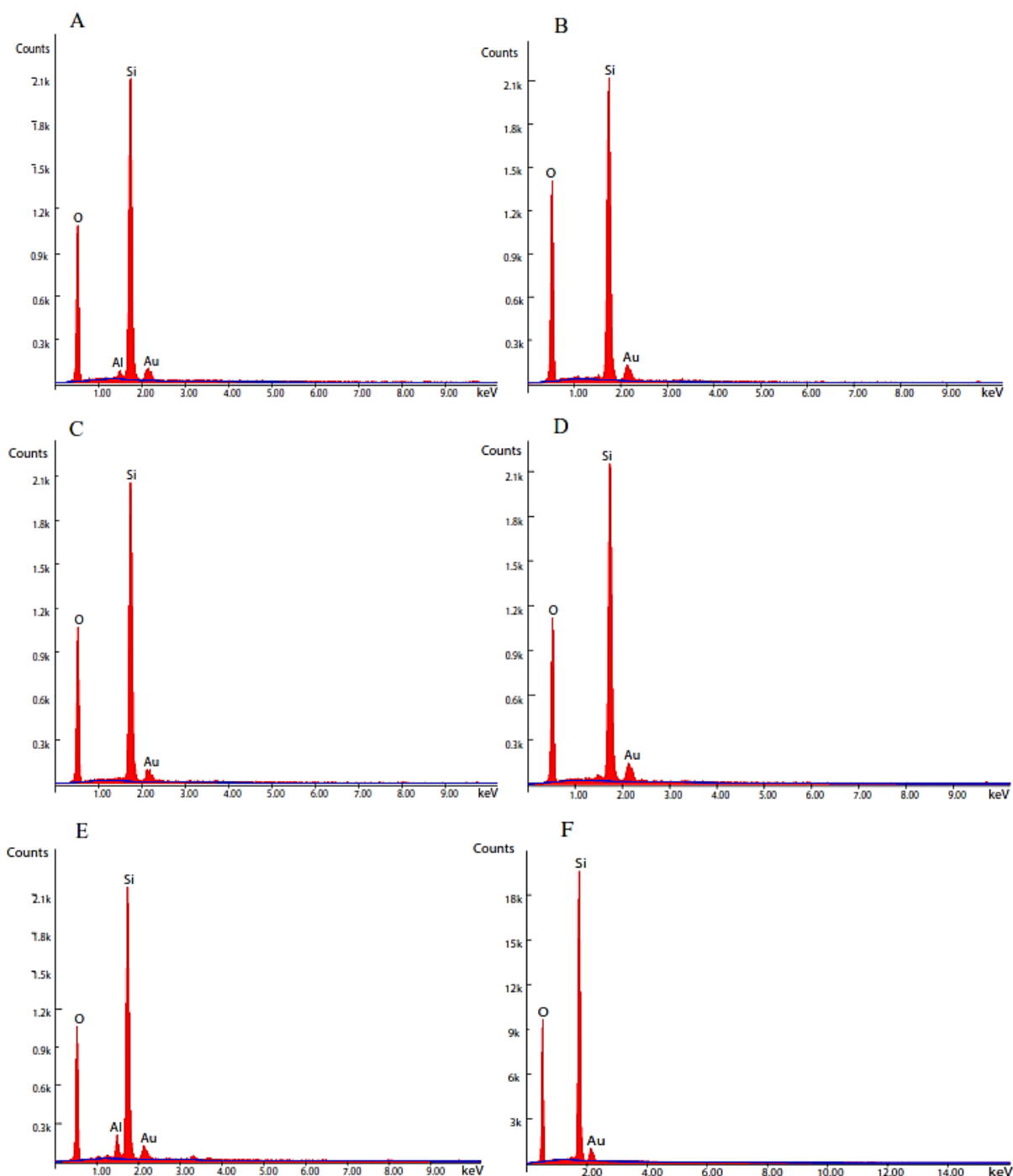

Fig. 7. Analysis of silica purity in some *Equisetum arvense* populations with energy-dispersive X-ray spectroscopy. A: Irde-Mousa (EAP1), B: Sarab (EAP4), C: Kandovan (EAP5), D: Tunnel-e-Kandovan (EAP6), E: Takor (EAP7), F: Marzanabad (EAP11).

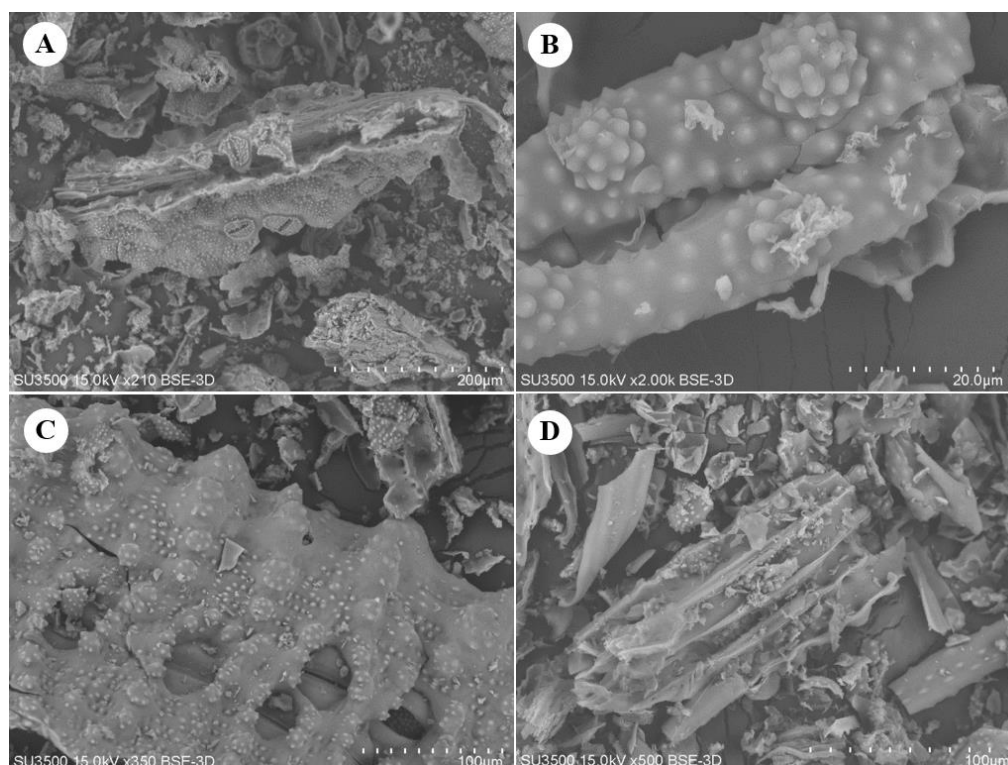

Fig. 8. Scanning electron microscopy (SEM) analysis of some *Equisetum arvense* populations (EAPs). A: Irde-Mousa (EAP1), B: Sarab (EAP4), C: Kandovan (EAP5), D: Tunnel-e-Kandovan (EAP6).

Table 6. Comparison of the weight percentage of the elements in the silica composition of *Equisetum arvense* populations studied

Population	Code	Element		
		Silicon	Oxygen	Aluminum
Irde-Mousa	EAP1	46.5	52.2	1.4
Hir	EAP2	45.0	53.0	2.0
Namin	EAP3	46.1	52.4	1.4
Sarab	EAP4	42.3	56.6	1.0
Kandovan	EAP5	46.2	52.8	1.0
Tunnel-e-Kandovan	EAP6	45.6	53.3	1.2
Takor	EAP7	46.4	49.8	3.7
Yush	EAP8	45.6	53.2	1.1
Chamestan	EAP9	46.7	52.1	1.2
Abbasabad	EAP10	44.3	53.2	2.4
Marzanabad	EAP11	46.9	52.1	1.0

4. Discussion

Variation in the morphological traits can be affected by genetic, environmental, and geographical conditions. The length of the vegetative stem and the plant width can be directly related to the genetic factors and growth conditions [16, 17].

Due to the susceptibility of the plant to high temperature and water deficiency, the dry weight of the plant stem was increased with increasing temperature. The similar results have been reported on *Satureja mutica* Fisch. & C.A. Mey [18] and on *Iochrominae* (Solanaceae) [19].

Common horsetail is a shade plant that is competing with the other accompanying plants in the habitats for the least light energy to grow and to evolve, which led to an increase in the plant internodes length. This is frequently seen in the plant populations which are growing on the northern slopes and shady forests. The populations of Sarab (*EAP4*), Hir (*EAP2*), and Irde-Mousa (*EAP1*) grow on loose, rocky, and shaded soils on the northern slope and are probably more elevated than other populations due to insufficient light. To compensate for light deficiency and to increase the level of light intake, *Equisetum* species increased the length of their branches. Subsequently, the rate of photosynthesis, growth, height, and dry weight of the plant stem is increased.

Several groups of secondary metabolites (SMs) including phenolics, flavonoids, alkaloids, nicotine, palustrine, palustrinin, phytoestrols (campstrol), and minerals (silica, calcium, and magnesium) have been reported from *Equisetum* species so far [20-22]. Caffeic acid, ferrulic acid, and quercetin have been also reported in the extract of *E. arvense* [23]. It is proposed that the difference in the SMs of different populations can be related to genetic, ontogenic, morphogenetic, locality, and environmental factors [6, 24].

Silica is a beneficial element to plants, and its absorption via transporters leads to protective effects against biotic and abiotic stresses [25]. The silica accounts for about 10 % of the fresh weight of horsetail which leads to enhance the plant strength and stability. It is absorbed through

the plant roots as $\text{Si}(\text{OH})_4$ and is presented as a monomer-free molecule at a $\text{pH} < 9$ [10]. Silica has been reported to increase collagen synthesis and help bone mineralization [13].

SEM analysis has been used for the characterization of the ash in some plants such as *Pinus sylvestris* [26], *Oryza sativa* [27], and Mustard [28] so far.

In a local study in the east of Mazandaran Province of Iran, it has been revealed that the content of elements in the vegetative stems of *E. telmateia* are affected by the altitude of the collection site. Their results showed that the content of nitrogen, zinc, and silica increased at low altitudes (150-250 m above sea level), but the content of phosphorus, potassium, calcium, magnesium, iron, manganese, and copper was higher at high altitudes (1100-900 m). Specific transporters are present in the root of horsetail to transport silica in the plant roots. This hypothesis has recently been confirmed by sequencing the genome of silica transporters in the cell membrane at the plant root.

5. Conclusion

The present study was provided a preliminary information about agro-morphological and phytochemical diversity and silica content of some Iranian EAPs for the first time. Marzanabad (*EAP11*) and Sarab (*EAP4*) were distinguished as adequate populations based on morphological traits such as stem height and shoot dry weight. Marzanabad population with the highest content of total phenol, total flavonoid, *p*-coumaric acid, and isoquercitrin as

well as the population of Irde-Mousa (*EAPI*) with the highest silica content can be strongly recommended for further exploitation in conservation, domestication, breeding, and mass production programs to cover pharmaceutical and cosmetic industries demand.

Author contributions

M. M. I-M. contributed to the conception of the study, plant materials collection, statistical analysis, and interpretation of data. M.H. M. advised the study, wrote and revised the manuscript. S. R. carried out formal analysis and wrote the first draft of the manuscript. A. S. helped in plant materials collection and identification. S. N. E. carried out HPLC

analysis. J. H. supervised the whole experiments and revised the manuscript. All authors read and approved the final manuscript.

Conflict of interest

The authors declare that they have no competing interests.

Acknowledgement

The authors thank the Research Council of Shahid Beheshti University, Tehran, Iran for their financial support. We also wish to thank Mr. Mohsen Shahnani and Mr. Hamid Ahadi for their kind help in silicon extraction and HPLC analysis, respectively. Collaboration of Tochal Pharma Co. is kindly appreciated.

References

1. Chen S-L, Yu H, Luo H-M, Wu Q, Li C-F and Steinmetz A. Conservation and sustainable use of medicinal plants: problems, progress, and prospects. *Chinese Medicine* 2016; 11(1): 1-10. doi: <https://doi.org/10.1186/s13020-016-0108-7>.
2. Rajpurohit D and Jhang T. In situ and ex situ conservation of plant genetic resources and traditional knowledge. In: *Plant Genetic Resources and Traditional Knowledge for Food Security*. Vol: Springer; 2015, 137-162. doi: https://doi.org/10.1007/978-981-10-0060-7_8.
3. Sofowora A, Ogunbodede E and Onayade A. The role and place of medicinal plants in the strategies for disease prevention. *African Journal of Traditional, Complementary and Alternative Medicines* 2013; 10(5): 210-229. doi: <http://doi.org/10.4314/ajtcam.v10i5.2>.
4. Kumar P. The Economics of Medicinal Plants: Are High Commercial Values Enough to Ensure Biodiversity Conservation? A perspective. IUCN. 2006: 9.
5. Ghorbani S, Esmaili H, Ebrahimi SN, Palazon J, Sonboli A and Mirjalili MH. Genetic structure, molecular and phytochemical analysis in Iranian populations of *Ruscus hyrcanus* (Asparagaceae). *Industrial Crops and Products* 2020; 154: 112716. doi: [doi: 10.1016/j.indcrop.2020.112716](https://doi.org/10.1016/j.indcrop.2020.112716).
6. Selseleh M, Hadian J, Ebrahimi SN, Sonboli A, Georgiev MI and Mirjalili MH. Metabolic diversity and genetic association between wild populations of *Verbascum songaricum* (Scrophulariaceae). *Industrial Crops and Products* 2019; 137: 112-125. doi: [10.1016/j.indcrop.2019.03.069](https://doi.org/10.1016/j.indcrop.2019.03.069).
7. Hadian J, Hossein Mirjalili M, Reza Kanani M, Salehnia A and Ganjipoor P. Phytochemical and morphological characterization of *Satureja*

- khuzistanica* Jamzad populations from Iran. *Chemistry & Biodiversity* 2011; 8(5): 902-915. doi: <https://doi.org/10.1002/cbdv.201000249>.
- 8.** Mozaffarian V. A dictionary of Iranian plant names, Farhang Moaser. in Tehran: Iran. Farhang Moaser Publishing. 2009, 542-544.
- 9.** Kalbadi A. Flora of Iran, No. 61: Equisetaceae. Forests and Rangelands Research Institute; 2009.
- 10.** Sandhu NS, Kaur S and Chopra D. Equisetum arvense: pharmacology and phytochemistry-a review. *Asian Journal of Pharmaceutical and Clinical Res.* 2010; 3(3): 146-150.
- 11.** Mimica-Dukic N, Simin N, Cvejic J, Jovin E, Orcic D and Bozin B. Phenolic compounds in field horsetail (*Equisetum arvense* L.) as natural antioxidants. *Molecules* 2008; 13(7): 1455-1464. doi: 10.3390/molecules13071455.
- 12.** Uslu M, Mele A and Bayraktar O. Evaluation of the hemostatic activity of *Equisetum arvense* extract: The role of varying phenolic composition and antioxidant activity due to different extraction conditions. *Biointerface Res. Appl. Chem.* 2019; 9: 4157-4163. doi: 10.33263/BRIAC94.157163.
- 13.** Badole S and Kotwal S. Evaluation of proximate, free radical scavenging activity, and phytochemical analysis of *Equisetum arvense* L. extracts. *Indian Journal of Natural Products and Resources (IJNPR)*[Formerly Natural Product Radiance (NPR)]. 2017; 8(2): 146-150.
- 14.** Bayati M, Tavakoli MM, Ebrahimi SN, Aliahmadi A and Rezadoost H. Optimization of effective parameters in cold pasteurization of pomegranate juice by response surface methodology and evaluation of physicochemical characteristics. *LWT.* 2021; 147: 111679. doi: 10.1016/j.lwt.2021.111679.
- 15.** Kamtekar S, Keer V and Patil V. Estimation of phenolic content, flavonoid content, antioxidant and alpha amylase inhibitory activity of marketed polyherbal formulation. *Journal of Applied Pharmaceutical Science* 2014; 4(9): 61. doi: 10.7324/JAPS.2014.40911.
- 16.** Andi SA and Maskani F. Essential oil chemical diversity of twenty Iranian *Origanum vulgare* L. subsp. viride populations. *Biochemical Systematics and Ecology* 2021; 98: 104323.
- 17.** Hailu T, Feyissa T, Dekebo A, Hailemichael G and Gadissa F. Diversity in capsule and seed morphological and phytochemical features and essential oil composition of korarima (*Aframomum corrorima* (braun) PCM jansen) collections from Ethiopia. *Biochemical Systematics and Ecology* 2021; 97: 104275.
- 18.** Khadivi-Khub A, Karimi E and Hadian J. Population genetic structure and trait associations in forest savory using molecular, morphological and phytochemical markers. *Gene* 2014; 546(2): 297-308. doi: 10.1016/j.gene.2014.05.062.
- 19.** Berardi AE, Hildreth SB, Helm RF, Winkel BS and Smith SD. Evolutionary correlations in flavonoid production across flowers and leaves in the Iochrominae (Solanaceae). *Phytochemistry* 2016; 130: 119-127. doi: 10.1016/j.phytochem.2016.05.007.
- 20.** Oniszczyk A, Podgórski R, Oniszczyk T, Żukiewicz-Sobczak W, Nowak R and Waksmundzka-Hajnos M. Extraction methods for the determination of phenolic compounds from *Equisetum arvense* L. herb. *Industrial*

Crops and Products 2014; 61: 377-381. doi: 10.1016/j.indcrop.2014.07.036.

21. Pallag A, Jurca T, Pasca B, Sirbu V, Honiges A and Costuleanu M. Analysis of phenolic compounds composition by HPLC and assessment of antioxidant capacity in *Equisetum arvense* L. extracts. *Revista de Chimie*. 2016; 67(8): 1623-1627.

22. Uslu ME, Erdoğan İ, Bayraktar O and Ateş M. Optimization of extraction conditions for active components in *Equisetum arvense* extract. *Rom. Biotechnol. Lett.* 2013; 18: 8115-8131.

23. Čanadanović-Brunet JM, Četković GS, Djilas SM, Tumbas VT, Savatović SS, Mandić AI, Markov SL and Cvetković DD. Radical scavenging and antimicrobial activity of horsetail (*Equisetum arvense* L.) extracts. *International Journal of Food Science & Technol.* 2009; 44(2): 269-278. doi: 10.1111/j.1365-2621.2007.01680.x.

24. Verma N and Shukla S. Impact of various factors responsible for fluctuation in plant secondary metabolites. *Journal of Applied Research on Medicinal and Aromatic Plants* 2015; 2(4): 105-113. doi: 10.1016/j.jarmap.2015.09.002.

25. Vivancos J, Deshmukh R, Grégoire C, Rémus-Borel W, Belzile F and Bélanger RR. Identification and characterization of silicon efflux transporters in horsetail (*Equisetum arvense*). *Journal of Plant Physiol.* 2016; 200: 82-89. doi: 10.1016/j.jplph.2016.06.011.

26. Dibdiakova J, Wang L and Li H. Characterization of ashes from *Pinus sylvestris* forest biomass. *Energy Procedia*. 2015; 75: 186-191. doi: 10.1016/j.egypro.2015.07.289.

27. Xu W, Lo TY and Memon SA. Microstructure and reactivity of rich husk ash. *Construction and Building Materials* 2012; 29: 541-547. doi: 10.1016/j.conbuildmat.2011.11.005.

28. Trivedi NS, Mandavgane SA and Kulkarni BD. Mustard plant ash: a source of micronutrient and an adsorbent for removal of 2,4-dichlorophenoxyacetic acid. *Environmental Science and Pollution Research*. 2016; 23: 20087-20099. doi: 10.1007/s11356-016-6202-7.

How to cite this article: Malekpour Irde-Mousa M, Mirjalili MH, Rahimi S, Sonboli A, Nejad Ebrahimi S, Hadian J. Agro-morphological and phytochemical diversity and silica content variability among Iranian populations of common horsetail (*Equisetum arvense* L.). *Journal of Medicinal Plants* 2021; 20(80): 83-101. doi: 10.52547/jmp.20.80.83

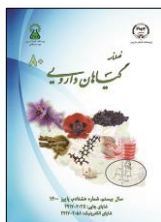

فصلنامه گیاهان دارویی

Journal homepage: www.jmp.ir

مقاله تحقیقاتی

تنوع آگرومورفولوژیکی و فیتوشیمیایی و محتوای سیلیس در جمعیت‌های ایرانی دم اسب صحرائی مهدی ملک‌پور ایردموسی^۱، محمدحسین میرجلیلی^{۱*}، سارا رحیمی^۱، علی سنبلی^۲، صمد نژاد ابراهیمی^۳، جواد هادیان^۱
^۱ گروه کشاورزی، پژوهشکده گیاهان و مواد اولیه دارویی، دانشگاه شهید بهشتی، ۱۹۸۳۹۶۹۴۱۱، تهران، ایران
^۲ گروه بیولوژی، پژوهشکده گیاهان و مواد اولیه دارویی، دانشگاه شهید بهشتی، ۱۹۸۳۹۶۹۴۱۱، تهران، ایران
^۳ گروه فیتوشیمی، پژوهشکده گیاهان و مواد اولیه دارویی، دانشگاه شهید بهشتی، ۱۹۸۳۹۶۹۴۱۱، تهران، ایران

چکیده

اطلاعات مقاله

مقدمه: گیاه دم اسب (*Equisetum arvense* L.) به واسطه داشتن عنصر سیلیس، بطور گسترده در تولید محصولات گیاهی تقویت کننده ناخن و مو استفاده می‌شود. **هدف:** تنوع آگرومورفولوژیکی، فیتوشیمیایی و محتوای سیلیس جمعیت‌های دم اسب صحرائی جمع‌آوری شده از ایران به همراه دو نمونه تجاری گیاه از روسیه و سوئیس مورد بررسی قرار گرفت. **روش بررسی:** صفات مورفولوژیکی توسط خط کش و کولیس دیجیتال، چشم غیر مسلح و ترازوی دیجیتال اندازه‌گیری شدند. صفات فیتوشیمیایی توسط اسپکتروفتومتر و کروماتوگرافی مایع با کارایی بالا همراه با طیف سنج جرمی ارزیابی شدند. محتوای سیلیس توسط طیف سنجی اشعه ایکس آنالیز شد. **نتایج:** حداکثر ارتفاع گیاه در جمعیت سراب مشاهده شد، در حالیکه بیشترین پهنای بوته و وزن خشک ساقه در جمعیت مرزن آباد مشخص شد. بیشترین محتوای تام فنلی و فلاونوئیدی به ترتیب در نمونه روسیه و جمعیت مرزن آباد اندازه‌گیری شد. بر اساس نتایج کروماتوگرافی، محتوای ایزوکوئرستین از ۰/۰۳ تا ۳/۰۵ میلی گرم بر گرم ماده خشک به ترتیب در نمونه روسیه و جمعیت مرزن آباد متغیر بود، در حالیکه محتوای سیلیس در بین نمونه‌ها از ۳۰ تا ۸۷/۵ میلی گرم بر گرم ماده خشک به ترتیب در جمعیت چمستان و ایردموسی متغیر بود. **نتیجه‌گیری:** در این مطالعه، جمعیت‌های مرزن آباد و سراب از نظر صفات مورفولوژیکی برتر بودند. جمعیت مرزن آباد از نظر صفات فیتوشیمیایی برتر بود که می‌تواند به خوبی در برنامه‌های حفاظتی، اهلی‌سازی و تولید انبوه گیاه مورد توجه قرار گیرد. در ارتباط با محتوای سیلیس، جمعیت ایردموسی به عنوان جمعیت برتر مشخص گردید که می‌تواند در تولید فرآورده‌های گیاهی تقویت‌کننده استخوان، مو و ناخن مورد بهره‌برداری تجاری قرار گیرد.

گل‌واژگان:

دم اسب

دم اسب

ایزوکوئرستین

سیلیس

تنوع

مخفف‌ها: MAPs، گیاهان دارویی و معطر؛ EAPs، جمعیت‌های دم اسب صحرائی؛ TPC، محتوای تام فنلی؛ TFC، محتوای تام فلاونوئیدی؛ MPH، هراباریوم پژوهشکده گیاهان و مواد اولیه دارویی؛ DW، وزن خشک؛ DMSO، دی متیل سولفوکساید؛ PDA، دکتور آرایه فوتودیود؛ HPLC، کروماتوگرافی مایع با کارایی بالا؛ EDAX، طیف سنج اشعه ایکس؛ SEM، میکروسکوپ الکترونی روبشی؛ SMS، متابولیت‌های ثانویه * نویسنده مسؤول: m-mirjalili@sbu.ac.ir

تاریخ دریافت: ۲۴ مهر ۱۴۰۰؛ تاریخ دریافت اصلاحات: ۹ آذر ۱۴۰۰؛ تاریخ پذیرش: ۹ آذر ۱۴۰۰

doi: 10.52547/jmp.20.80.83

© 2020. Open access. This article is distributed under the terms of the Creative Commons Attribution-NonCommercial 4.0 International License (<https://creativecommons.org/licenses/by-nc/4.0/>)